

Research Paper

# Analysis of Speed Profiles at an Unsignalised Intersection for Left Turning Vehicles

Maryam Dolatalizadeh<sup>1</sup>, Amin Mirza Boroujerdian<sup>2\*</sup>, Seyed Ehsan Seyed Abrishami<sup>3</sup>

## Abstract

Intersections are one of the elements that play an important role in urban networks. Analysis of drivers' performance at unsignalised intersections is crucial, especially in left-turning movements due to their several inherent conflicts and variety of drivers' maneuver types which affect traffic safety and capacity at such intersections, so the purpose of this paper is to introduce how the behaviour of drivers will be specified in left-turning at unsignalized intersection. For this study, traffic data were collected using a fixed digital camera. First, the vehicle speed profiles are categorized into descending-ascending slope (type (A)), the smooth descending-ascending slope (type (B)) and ascending slope (type (C)). The effects of the initial speed of left-turning vehicles, the exposure with other vehicles, and the vehicle type (i.e., taxi versus other vehicles) are investigated on the choice of speed profile. A multinomial logit model is utilized to explain how various variables influence the choice of speed profile. The estimated model indicates that the initial speed and the exposures are influential parameters. Also, vehicles with left exposure at intersections increase the drivers' tendency for selecting type (A) profile while they have low to medium initial speeds when entering the intersections. For the vehicles with high initial speeds, most drivers pass the intersection with type (B) profile. Vehicles with low initial speeds and a low number of exposures increase the probability of selecting type (C) profile. Introduced method can be applied for simulation models at unsignalised intersection to show how drivers will behave in left-turning movements.

**Keywords:** Speed profile; unsignalised intersection; left turning; multinomial logit model

---

Corresponding author E-mail: boroujerdian@modares.ac.ir

1.Ph.D Candidate, Department of Civil and Environmental Engineering, Tarbiat Modares University, Tehran, Iran

2.Assistant Professor, Department of Civil and Environmental Engineering, Tarbiat Modares University, Tehran, Iran.

3.Assistant Professor, Department of Civil and Environmental Engineering, Tarbiat Modares University, Tehran, Iran

## 1. Introduction

Intersections are one of the most important elements in urban networks that a significant portion of urban crashes fall at them whose safety analysis should be taken into account to manage safety in cities [Sun et al. 2012] or traffic simulation. The simulation models use predicting models of driver behaviour that can be a function of vehicle, environment, road, and human factors. The purpose of this paper is to introduce how the behavior of drivers will be specified in left-turning movement at unsignalized intersection, so a method is introduced that uses a two-step analysis to determine driving behaviour in passing an unsignalised intersection, including 1. Categorizing of the vehicles' speed profiles, 2. Developing a multinomial logit model (MNL) for selecting a speed profile. The main contribution is the determining of the speed profiles in different conditions in the left turning movement by drivers. The determining of turning speed in microscopic model needs to calibrate that the speed profiles and the results of this paper can be used for this object. To indicate the process of implementing the suggested method, an urban unsignalised intersection is selected. First, traffic data are collected with a digital camera since this method provides the data analysis with high accuracy at micro level. The videos are analyzed with Kinovea software. The coordinates of the left-turning vehicles from minor to major approaches are extracted and the speed profiles are drawn based on the movement coordinates. Then, these speed profiles are categorized into three types based on their shapes. To obtain the effected variables in the choice of the speed profiles, the MNL model is developed on the data. The results show that the initial speed (the left turning vehicle's speed when entering the intersection) and the exposures with left-turning vehicles are effective. The results of the

presented method can be used in simulations for predicting the movements at the intersections.

## 2. Literature Review

Previous studies on the current subject have focused on drivers' crossing behaviour at unsignalised and signalised intersections. Laureshyn, Åström and Brundell-Freij [Laureshyn, Åström and Brundell-Freij, 2009] classified speed profiles of left-turning vehicles at a signalised intersection by pattern recognition techniques (e.g., cluster analysis, supervised learning, and dimension reduction). They classified traffic conditions into three scenarios: an observer that considered no on-coming traffic pedestrians, driver yields to the on-coming vehicles, and driver yields to the pedestrian crossing. The results indicated that the pattern recognition techniques have the capability to classify speed profiles. Wolfermann, Alhajyaseen, and Nakamura [Wolfermann, Alhajyaseen, and Nakamura, 2011] evaluated speed profiles of right and left-turning vehicles at signalised intersections. They utilized the regression model for modelling of speed, acceleration, and jerk profiles. The results showed that speed profiles are sensitive to intersection layout, namely the approach angle, the curb radius, and the position of the hard nose. Also, the profiles had a random distribution that depended on the approach of exit vehicle speed and its lateral position in the exit. Platho, Groß and Eggert [Platho, Groß and Eggert, 2013] proposed an approach to predict the performance in complex traffic situations. This method evaluated driving situation for each vehicle that stopped by the red traffic light, by leading vehicle, and by intersection. Then, we employed this information to select a specific model for predicting its future velocity profile. Random Forest Regression method was employed as a prediction method. For prediction process of

## Analysis of Speed Profiles at An Unsignalised Intersection for Left Turning Vehicles

vehicle's velocity profile, we employed some features such as velocity and acceleration of that vehicle, distance to stopping line of the next relevant traffic light, relative velocity and relative distance between that vehicle and its leading vehicle, distance to the entry point of the next intersection and time instance for predicting velocity. Li et al. [Li et al. 2016] analyzed the characteristics of conflict between left-turning vehicles and illegally crossing pedestrians in the affected region at signalised intersection. Four modes of driving behaviour of left-turning vehicles were considered that included crossing at a uniform speed, crossing while decelerating, crossing slowly, braking, and stopping. A cellular automata model was used to simulate the driving behaviour and a logit model of the behaviour mode choice was also developed to analyze the relative share of each behaviour mode. The most important factors used in the choice model included the time required for a vehicle to cross the intersection, the time required for an illegally crossing pedestrian to cross the affected region and the time required for a pedestrian to cross the crosswalk. Finally, the microscopic characteristics of driving behaviours (i.e., instantaneous velocities, locations, and headway of individual vehicles) and the macroscopic parameters of traffic flow (i.e., average flow, density, and speed) were determined. Dias, Iryo-Asano and Oguchi [Dias, Iryo-Asano and Oguchi, 2017] estimated the path of left-turning vehicles at signalised intersections based on speed and acceleration profiles simultaneously. Minimum-jerk theory was proposed to model trajectories for turning vehicles. Variables, including initial and final speeds, initial and final accelerations, and the movement time were used to solve the cost function in the theory. The results showed that this modelling process reproduced turning trajectories with reasonable accuracy compared to the results of previous studies. Ma et al. [Ma et al. 2017] developed a

two-dimensional simulation for turning movement at mixed-flow intersection. They used a three-layered, "plan-decision-action", framework to determine turning parameters. First, trajectories were characterized, then driving behaviour was selected among three alternatives that included car-following, turning, and yielding. Finally, acceleration and angular velocity in left-turning movements were calculated. The model improved the performance of simulation from two aspects of traffic efficiency and safety. Armand, Filliat and Ibanez-Guzman [Armand, Filliat and Ibanez-Guzman, 2013] applied Gaussian Processes to model the velocity profile that the driver follows as the vehicle decelerates towards a stop intersection. It was shown that Gaussian Processes are well adapted for such an application, using data recorded in real traffic conditions. Lu et al. [Lu et al. 2015] studied crossing behaviour of straight-moving drivers when they encountered other straight-moving drivers at unsignalised intersections with the logit model. The dependent variable of the model was straight-moving vehicle status (preemptive=1, yielding=0). The survey indicated that the most significant parameters that affected drivers' decisions were relative speed between the right vehicle and left vehicles, the relative distance between the right vehicle to the crossing point and the left vehicle to the crossing point, and the relative distance between the right and left vehicles. The results of decision-making time indicated that the straight-moving drivers from the right side completed preemptive/yielding decisions at 1.3 s before reaching the crossing point and this time for drivers from the left side is equal to 1.1 s. The most important parameter that influenced the drivers' decisions was the difference between the speeds of two vehicles. Patil and Pawar [Patil and Pawar, 2016] surveyed traffic parameters, such as traffic composition, speed variations, lane distribution, trajectories, conflict points, and

**Maryam Dolatalizadeh, Amin Mirza Boroujerdian, Seyed Ehsan Seyed Abrishami**

pedestrian movements for unsignalised intersections. The authors extracted speed values from the intersections. The results showed that the speed at inner lane was higher than outer lane vehicles. Meanwhile, minor approach vehicles decreased their speed or stopped many times. Trajectories of two-wheelers were found to be much flatter than the trajectories in the standard conflict point diagram. Zhang, Qi, and Chen [Zhang, Qi and Chen, 2016] evaluated left-turning movements from minor road approach at unsignalised intersections. The binary logistic analysis showed that parameters such as slower speed of vehicles on the major or minor road and more lanes on the minor road could cause drivers to select normal vehicle paths.

Liu et al. [Liu et al. 2016] investigated the behaviour of two straight-moving vehicles from an orthogonal direction at unsignalised intersection whose study focused on drivers' risk perception. They used effective parameters in drivers' behaviour based on their previous study Lu et al. [Lu et al. 2015] for developing models of drivers' risk perception by ANFIS. Then, a model established by game theory to determine the relationship between risk perception value and vehicle movement strategies that included acceleration, uniform motion, and deceleration.

Finally, vehicle speed and the distance from a vehicle to the crossing point were calculated by analyzing the Nash equilibrium strategy.

Li et al. [Li et al. 2019], Surveyed the drivers' visual scanning behavior at signalized and unsignalized intersections in china. The results showed that in left turning, drivers near signalized intersections had more frequent glances at the left view mirror, fixated much longer on the forward and rear view mirror area, and had higher transition probabilities from near left to far left. Compared with drivers' scanning patterns in left turning maneuver at signalized intersections, drivers with higher situation awareness levels would divide more attention to the forward and right areas than at unsignalized intersections.

The survey research of the past studies indicate some methods and effective parameters to evaluate driving behaviour at the intersections. In this study, a simple method is presented to extract behavioral model of drivers for such intersections and for determining of the effective parameters on the driving behaviour is used from the previous researches. Table 1 shows the studies investigating drivers' behaviour at signalised and unsignalised intersections.

## Analysis of Speed Profiles at An Unsignalised Intersection for Left Turning Vehicles

**Table 1. Summary of previous studies on drivers' behaviour at the intersection**

Author (Year)	Problem Definition	Methodology	Conclusions
<b>Signalised Intersection</b>			
Laureshyn, Åström and Brundell-Freij (2009)	Classifying speed profiles of left turning vehicles	Pattern recognition techniques	Proposed framework is well method for classification of speed profiles
Wolfermann, Alhajyaseen and Nakamura (2011)	Modelling of speed profiles of turning vehicles	Regression models	Speed profiles are sensitive to intersection geometry
Platho, Groß and Eggert (2013)	An approach for predicting performance in complex traffic situations	Two-stage simulation	Development of a classifier for driving situation and a regressor for velocity profile prediction
Li et al (2016)	Analyzing of conflict between left-turning vehicles and pedestrians	Cellular Automata model	Determination of microscopic characteristics of driving behaviours and macroscopic parameters of traffic flow
Dias, Iryo-Asano and Oguchi (2017)	Prediction of path of left turning vehicle	Minimum-jerk theory	Modelling process reproduced turning trajectories with a reasonable accuracy
Ma et al (2017)	a two-dimensional simulation for turning movement at mixed flow intersection	“plan-decision-action” framework	The model improved the performance of simulation from two aspects of traffic efficiency and safety
<b>Unsignalised Intersection</b>			
Armand, Filliat and Ibanez-Guzman (2013)	Modelling of velocity profile in stop intersection approaches	Gaussian Processes	Gaussian Processes are well adapted for data recorded in real traffic conditions
Lu et al (2015)	Surveying of behaviour of straight movements with together	Logit model	The most important parameter that influenced the drivers' decisions was the difference between the speeds of the two vehicles
Patil and Pawar (2016)	Surveying of traffic parameters at intersection	Descriptive statistics	One of the most important conclusions was that minor approach vehicles decreased their speed or stopped many times
Zhang, Qi and Chen (2016)	Evaluation of left turning movements from minor road approach	Binary logistic analysis	Slower speed of vehicles on major or minor road and more lanes on minor road were effective on choice of normal vehicle paths

Liu et al (2017)	Modelling crossing behaviour of drivers at unsignalised intersection with consideration of risk perception	Game theory	Determining of vehicle speed and the distance from a vehicle to the crossing point
------------------	--	-------------	--

### 3. Methodology

#### 3.1 Data Collection

In this study, Vesaleshirazi-Bozorgmehr intersection is selected in Tehran. This intersection is a four-leg unsignalised intersection whose approaches are perpendicular to each other and there is a median, stop line and the pedestrian crossing each of them. There are two lanes in each of the minor approaches and three lanes in each of the major approaches. The reason to select this intersection was the looking for an unsignalized intersection and taking video above the intersection, and also all videos had to be analyzed with image processing software and also it was needed an uncongested unsignalized intersection with high volume of left-turning movements that there was a high building that it could install the camera to take videos so this intersection was the best choice among all other choices. Figure 1 shows a view of both the intended intersection and considered movements for this research.

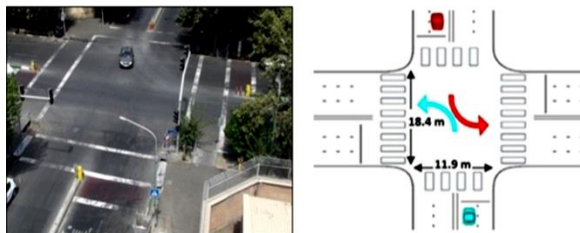

Figure 1. View of case study and tracked movement at the intersection

There are different methods for collection of traffic data, such as field observers, simulation models, and video analysis. [El-Basyouny and Sayed, 2013, Boroujerdian, Karimi and Seyed abrishami, 2014]. The data collection by observers may be accompanied by an error [Lu et al. 2012]. Also, simulation models do not account for the diverse and less predictable driver behaviour that exists in real road traffic. Because of the major limitations associated with collecting conflict data through field observers and simulation models, video analysis is a useful method to analyse driving behaviour at microlevel [Autey, Sayed, and Zaki, 2012, El-Basyouny and Sayed, 2013].

In this study, traffic data were collected using a digital camera fixed on a building near the intersection. The entrance traffic volume to the major approaches is between 600 and 1100 v/h and this volume for minor approaches is between 200 and 450 v/h. The composition of the different types of vehicles includes 61% passenger cars, 38% motorcycle, and 1% of other vehicles (heavy vehicles and van) in major approaches and 54% passenger cars, 36% motorcycle and 10% of other vehicles in minor approaches. For this study, 353 cases, including left-turning movements from minor to major approaches were extracted from videos.

#### 3.2 Data Processing

In this study, the video analysis is used for the analysis of the driving behaviour. Data are analyzed with Kinovea software that is the open-

## Analysis of Speed Profiles at An Unsignalised Intersection for Left Turning Vehicles

source software. This software is a video player for the movement analysis. It provides a set of tools for microscopic analysis of a video that gives movement characteristics, including the coordinates and the speed of the movement. For the analysis of left-turning movement, first, the vehicles coordinates in the pixels are converted to the real coordinates in road side by the camera calibration. Then, the vehicles are tracked by the software. Vehicle tracking is performed at 0.04 s intervals. The location of the vehicles and their speed are obtained and smoothed. Then, the speed profiles of left-turning vehicles are plotted on their movement trajectories. Figure 2 shows the process of drawing the speed profiles.

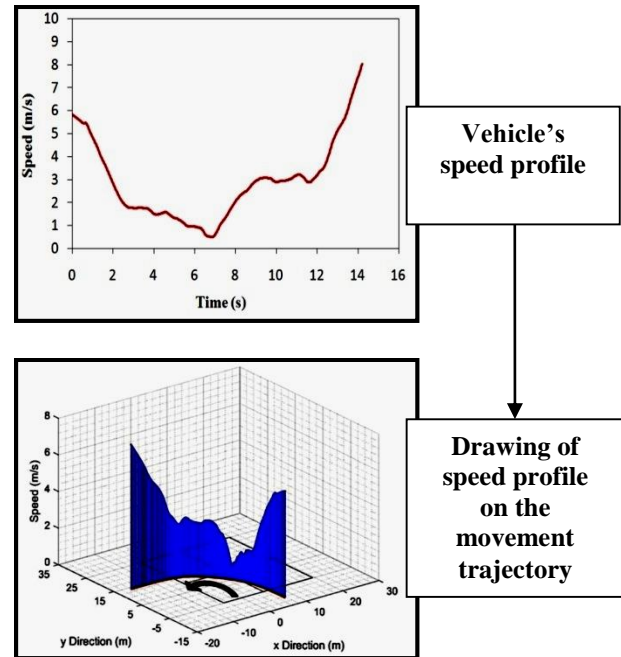
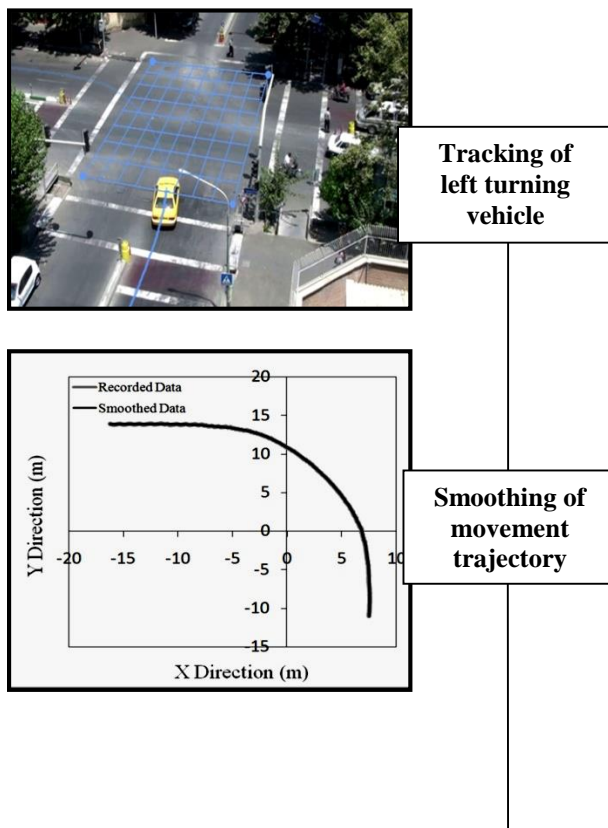

Figure 2. Process of drawing speed profiles

The plotted speed profiles are categorized based on the shape of the speed profiles. For this, it is used a qualitative evaluation. The shape of speed profiles is categorized based on the speed variations. To evaluate influence factors on the choice of the speed profiles type, five explanatory variables are considered that include the type of left-turning vehicle (taxi and other vehicles), initial speed of left-turning vehicle, its exposure with the vehicles from left approach, the exposure with the vehicles from right approach and the exposure with the vehicles from opposite approach. Then, an MNL model is developed for choosing the speed profiles. An MNL model is one of the discrete choice models that it is used when there are more than two alternatives for choice. In this study, there are three types of speed profiles as alternatives which are the discrete data, thus an MNL model is selected for the choice of the speed profile types. The general form of the MNL model is defined as follows:

$$Prob_i = \frac{\exp V_i}{\sum_{j=1}^J \exp V_j}; \quad j = 1, \dots, i, \dots, J \quad i \neq j \quad (1)$$

Where:

Prob<sub>i</sub>= probability of an individual choosing alternative i out of the set of J alternatives,  
 V<sub>i</sub>= observed utility index for alternative i,  
 V<sub>j</sub>= observed utility indices for all J alternatives.

And utility function is defined as follows [Hensher, Roseand Greene, 2005]:

$$V_i = \beta_{0i} + \beta_{1i}f(X_{1i}) + \beta_{2i}f(X_{2i}) + \beta_{3i}f(X_{3i}) + \dots + \beta_{ki}f(X_{ki}) \quad (2)$$

Where:

X<sub>ki</sub>= observed choice attributes and individual characteristics

β<sub>ki</sub> = parameter associated with attribute X<sub>k</sub> and alternative i,

β<sub>0i</sub> = a parameter not associated with any of the observed and measured attributes, called the alternative specific constant, which represents on average the role of all the unobserved sources of utility.

After determining the utility functions, sensitivity analysis is performed based on the calculated probability of the choice of the speed profile employing equation (1).

## 4. Data Analysis

### 4.1 Categorizing Speed Profiles Based on Their Shapes

The speed profiles are categorized into three types based on their shapes. For this, The speed profile of each vehicle extracted from videos and then a qualitative evaluation is used to define the speed profiles. The surveying of the trend of speed variations is indicated three categories of

speed profiles. The types of speed profiles are shown in Figure 3.

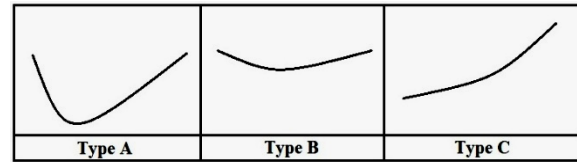

Figure 3. Types of speed profiles in the case study

Types (A) and (B) speed profiles exhibit a descending slope first, followed by an ascending slope. The difference between Types (A) and (B) speed profiles is that type (B) speed profile has a smoother slope than type (A) speed profile. Also, type(C) speed profile has a consistently ascending slope.

### 4.2 Influential Variables on Speed Profiles

Among total speed profiles, 48%, 27%, and 25% belong to type (A), type (B) and type (c), respectively.

#### 4.2.1 Vehicle Type Variable

It is hypothesized that the taxi drivers have different driving behaviours compared to the drivers of other vehicles. One possible explanation can be that taxi drivers spend more time on driving during a day than drivers of other vehicles. Therefore, taxi drivers are considered as the most experienced drivers and compared with usual drivers. As a result, the type of left-turning vehicle(taxi versus other vehicles) is selected as a variable in this study. Figure 4 shows speed profile types belonging to taxis and other vehicles.



## Analysis of Speed Profiles at An Unsignalised Intersection for Left Turning Vehicles

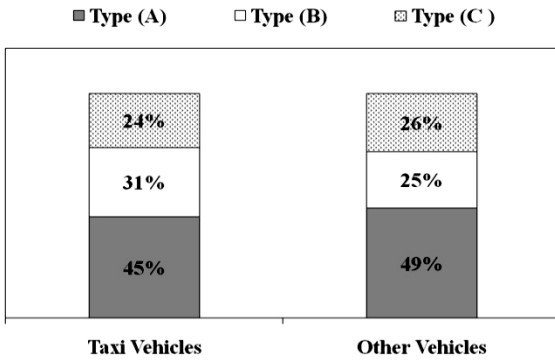

**Figure 4.**The percentage of speed profiles types in taxi and other vehicles

The results indicate that the choice of the speed profile is not affected by the vehicle type.

### 4.2.2 Initial Speed Variable

Investigation of the effect of initial speed of left-turning vehicle on the choice of the speed profile shows that many drivers who choose types (A) and (B) speed profiles have the initial speed over 10 km/h while most of the drivers who choose type (C) speed profile have the initial speed less than 20 km/h.

■ up to 10 km/h   ■ between 10 to 20 km/h   □ more than 20 km/h

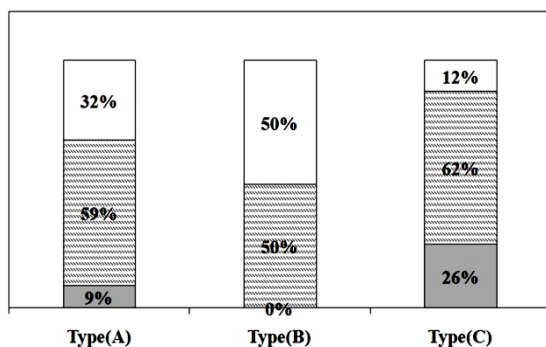

**Figure 5.**Ranges of the initial speed of vehicles in each speed profile category

It can be concluded that the drivers with higher initial speed tend to select a speed profile with a descending slope and then an ascending slope. Also, the collected data show that the highest percentage of maximum initial speed occurred in

type (B) speed profile, while the percentage of minimum initial speed in type (C) was higher than the other two types.

### 4.2.3 Exposures Variable

There is a hypothesis that when a driver sees a exposure, this affects his/her movement to avoid an accident.

In this study, for investigation of the influence of the exposures with left-turning vehicles on the choice of the speed profile type, two states are considered including the exposure from all approaches with left-turning vehicles and cases without any exposure as shown in Figure 6.

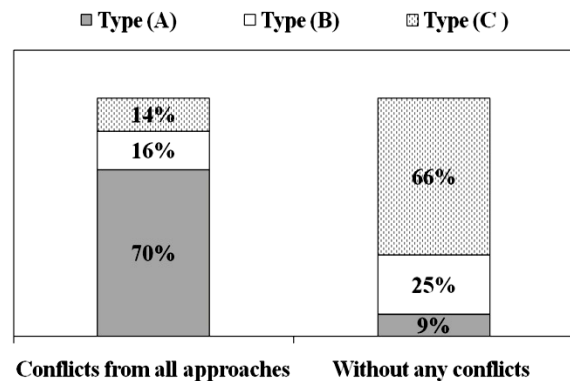

**Figure 6.** Distribution of speed profile types based on exposures from approaches

The evaluation indicated that 70% of the left-turn movements that have exposures with the vehicles from all other approaches exhibit type (A) speed profile, while 66% of left-turning vehicles without any exposures show type (C) speed profile. It indicates that the drivers choose type (C) speed profile in the scenarios with less risk and increase their speed when crossing the intersection.

## 4.3 Developing a choice model of speed profiles in left-turning movement

**Maryam Dolatalizadeh, Amin Mirza Boroujerdian, Seyed Ehsan Seyed Abrishami**

As mentioned above, speed profiles are categorized into three types. To develop a choice model, from each of left-turning observations, five explanatory variables are extracted that include the type of left-turning vehicle (taxi versus other vehicles), the initial speed of the left-turning vehicle (speed before arrival at the intersection) and possible exposures from one of the other three approaches. The vehicle type and the exposures from other approaches variables are defined as binary variables. If the vehicle type variable is a taxi thus it has a value of 1 and else 0. Also, if there is a exposure from each of the directions, the exposure variable has a value of 1 and else 0. Meanwhile, the initial speed variable is considered as a continuous variable.

An MNL model is used to explain how drivers choose their speed profile in left-turning movement. Utility functions for the speed profile are defined as follows:

$$\begin{aligned}
 U(\text{TypeA}) &= c_A + l_A \cdot L \\
 U(\text{TypeB}) &= c_B + s_B \cdot \text{Speed} \\
 U(\text{TypeC}) &= s_C \cdot \text{Speed} + r_C \cdot R + w_C \cdot W
 \end{aligned}
 \tag{3}$$

Where:

U(TypeA) = utility of type (A) speed profiles,

U(TypeB) = utility of type (B) speed profiles,

U(TypeC) = utility of type (C) speed profiles,  
Speed= the initial speed of left-turning vehicle (km/h),

L = the exposure with the vehicles from left approach,

R = the exposure with the vehicles from right approach,

W = the exposure with the vehicles from opposite approach,

$c_A, l_A, c_B, s_B, s_C, r_C$  and  $w_C$ = MNL model parameters.

The model is estimated using N-Logit software.

The results of the estimated model are presented in Table 2.

**Table 2. Results of the estimated model**

Type of Speed Profile	Variable	Coefficient	Std. Error	P value (sig.)
Type (A)	Intercept	-3.44949	0.58498	0.0000
	Exposure with vehicles from left major approach	1.51001	0.23494	0.0000
Type (B)	Intercept	-6.15867	0.76390	0.0000
	Initial speed	0.15447	0.03192	0.0000
Type (C)	Initial speed	-0.14704	0.03128	0.0000
	Exposure with vehicles from right major approach	-1.06499	0.28933	0.0002
	Exposure with vehicles from opposite minor approach	-1.04792	0.29407	0.0004

Number of Observation=353  
 Log Likelihood=-296.82569  
 AIC/N=1.721  
 Chi-Squared=151.09104  
 $\rho^2=0.203$   
 $\rho_c^2=0.190$

### 4.3.1 Modelling Results

The results of the estimated model show that each of the coefficients of the explanatory variables is significantly different from zero. The p-values of these variables are significant at the 99% confidence interval ( $p < 0.0001$ ) as shown in Table 2. Also, the chi-squared test of overall significance indicates that the model is significant at the 99% confidence interval (chi-squared < value, degree of freedom=5). This model shows that the exposure of left-turning vehicles with the vehicles from left major approach increases the probability of Choosing type (A) speed profile. The results show that the probability of choosing type (B) speed profile is increased by the increase of the initial speed. The model indicates that if the vehicle has a slower initial speed and there is not any vehicle in right major and minor opposite approach, the probability of choosing type (C) speed profile is increased.

### 5. Model Sensitivity Analysis And Interpretation

The sensitivity analysis of the impact of the explanatory variables on the probability of the choice of the speed profiles is conducted. For evaluation of the influence of the initial speed and the exposures on the choice behaviour of the speed profiles by the drivers, eight hypothetical exposure scenarios are considered as shown in Figure 7.

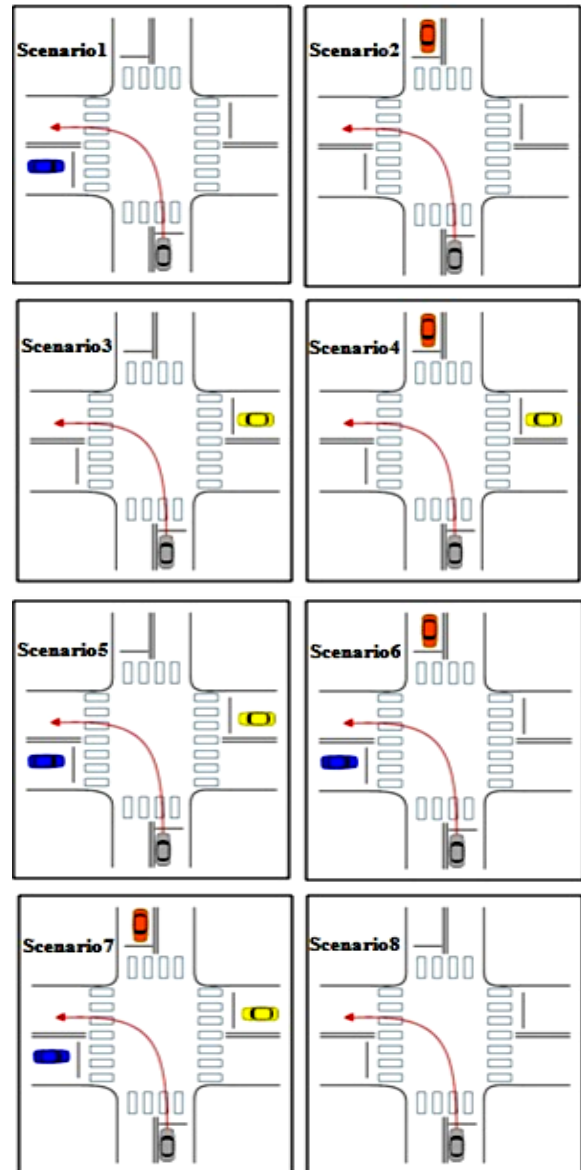
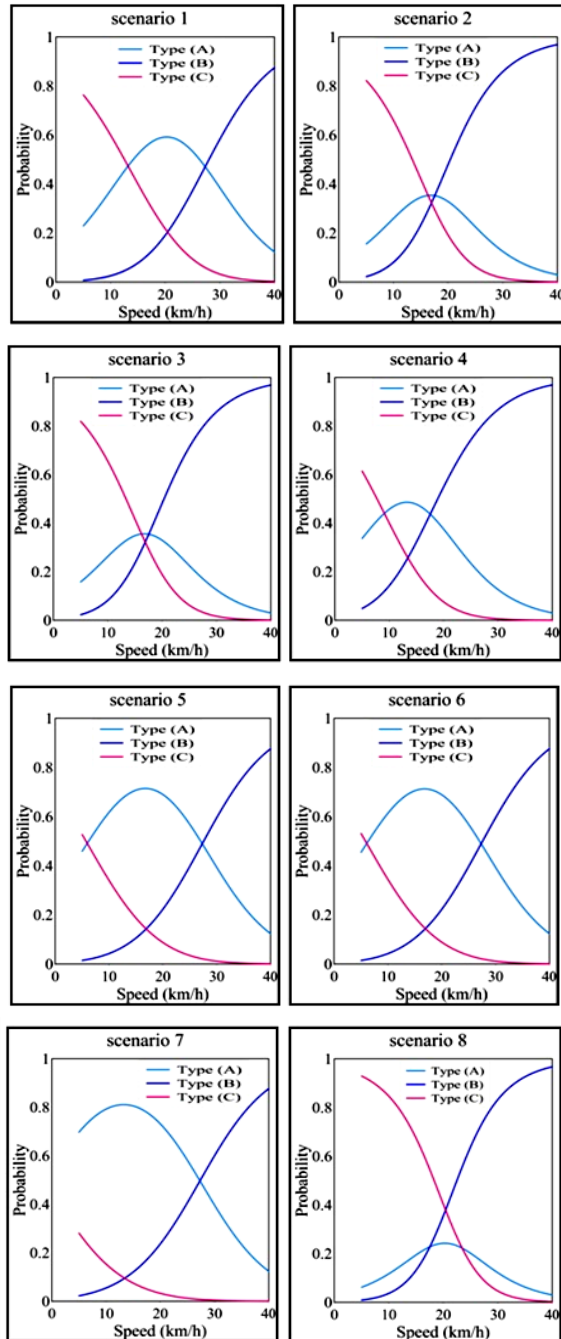

Figure 7. Hypothetical exposure scenarios

In each of the scenarios, the probability of the choice of each of the speed profiles is calculated at different initial speeds as shown in Figure 8.



**Figure 8. The choice probability of the speed profiles dependent on the initial speed and the exposure type**

It is hypothesized that the drivers whose initial speed is low check the traffic conditions of the intersection before arriving at the intersection

and after the finding the crossing priority, cross the intersection with increasing the speed thus, in the condition that there is not any exposure as illustrated in scenario 8 of Figure 8, the choice probability of type (C) speed profile is higher than the choice probability of other profile types at low to medium initial speeds. At medium to high speeds, while there is not any exposure, the choice probability of type (B) speed profile is higher than the choice probability of other profiles. In this condition, the drivers cross the intersection with confidence hence they increase their speed but also decrease their speed slightly in the middle of the intersection for more caution because of feeling high risk. By creating the exposure from an approach, the choice probability of type (C) speed profile is decreased. In scenarios 2 and 3 in which there is a exposure from the right and opposite approach, respectively the choice probability of type (C) speed profile is higher than other profile types at low to medium speeds and the choice probability of type (B) speed profile is higher than other profiles at medium to high speeds. Also, the choice probability of type (A) speed profile is increased rather than scenario 8 because the probability of the braking is increased with the existence of the exposure; however, the choice probability of type (A) profile is less than the choice probability of other profiles. In scenario 1, there is a exposure from the left approach. In this state, the choice probability of type (C) speed profile is higher than the choice probability of other profiles at low initial speeds while at medium initial speeds, the choice probability of type (A) speed profiles is higher than the choice probability of other profiles. Because in this scenario, the drivers pay attention to their left direction and they react with more focus on the left exposure. At high initial speeds, the choice probability of type (B) speed profiles is higher than the choice probability of other profiles. The choice of type (B) speed profile at high speeds

## Analysis of Speed Profiles at An Unsignalised Intersection for Left Turning Vehicles

despite the existence of the left exposure shows that the drivers are aggressive and they do not tend to decrease their speed so much. In scenario 4, the choice probability of type (C) speed profile is higher than other profiles at low initial speed. At medium initial speed, the choice probability of type (A) speed profile is higher than other profiles and the drivers exercise caution more than scenario 8, 2 and 3 and they prefer to brake for more numbers of the exposures and the information volume that they should process. The choice probability of type (B) speed profile is higher than other profiles at high initial speeds. At this range of speed, the drivers do not tend to decrease their speed and they might be aggressive drivers. In scenarios 5 and 6, similar to scenario 4, there are exposures from two directions, one from the left and the other from right or opposite direction. For left-turning movement, the drivers pay attention to the left more than other directions and they brake for more caution thus the choice probability of type (A) speed profiles is higher than other profiles at low to medium initial speeds. At medium to high speeds similar to scenario 4, the choice probability of type (B) speed profile is higher than other profiles. In scenario 7, for the exposures from all approaches, the drivers exercise more caution than other scenarios therefore the choice probability of type (A) speed profile is higher than other profiles at low to medium initial speeds. At medium to high speeds, the choice probability of type (B) speed profile is higher than other profiles. This indicates that in spite of the high level of initial speed and the exposures from all approaches, the drivers choose type (B) speed profiles, which might state that they are aggressive.

### 6. Discussion and Conclusions

This paper presents a method that uses a two-step analysis to determine driving behaviour while crossing the intersection: 1. Categorizing the

speed profiles, 2. Developing the MNL model for the choice of the speed profile. The mentioned intersection is a case study to indicate the process of implementing the suggested method to determine driving behaviour.

For this purpose, the speed profiles of left-turning vehicles at the unsignalised intersection are categorized into three types. Types (A) and (B) speed profiles show a descending initial slope followed by an ascending slope. The difference between Types (A) and (B) speed profiles is that type (B) is smoother than type (A) speed profile. Also, type (C) speed profile has a consistently ascending slope. This research shows that among 353 left-turning vehicles, about 50% of the speed profiles belong to type (A). Also, the percentage of the choice from each of the speed profile types is almost equal for taxi drivers and other vehicle drivers in a left turning movement. Evaluation of the initial speed indicated that most of the drivers who choose type (A) and type (B) speed profiles have an initial speed of more than 10 km/h, while most of the drivers who choose type (C) speed profile have the initial speed of less than 20 km/h. In 70% of the cases where the left turning vehicle has exposures with the vehicles from the other three approaches, type (A) speed profile is observed. Also in about 70 % of the cases that there are not any exposures, the left turning vehicle has type (C) speed profile.

After determining the categories of the speed profiles, the MNL model is used for the choice of these profiles. The model shows that such choice is depended on the initial speed and the exposures from other approaches.

Then, the sensitivity analysis is conducted for the evaluation of impact of the explanatory variables on the probability of the choice of the speed profiles. The results of these analyses indicate that the increasing number of exposures and the existence of the left exposure increase the drivers' tendency to choose type (A) speed profile at low to medium speeds. But when the

initial speed is high, most drivers cross the intersection with type (B) speed profile in all scenarios. It can be dangerous especially when the number of the exposures is high. In this condition, the methods such as the traffic calming can contribute to the safety of the intersection. Also, low initial speeds and low numbers of the exposures enhance the probability of the choice of type (C) speed profile.

Practical applications of this research can be followed as:

1. The extraction of the behavioral model of drivers in left-turning movement at

unsignalized intersection is very important in micro-simulation models and as various intersections may have different behavioral models, this study present a simple method to extract a behavioral model for such intersections.

2. The identification of drivers' behaviour in left turning will improve the parameters needed to calibrate simulation models at an unsignalised intersection that can be used to study safety or traffic at the intersection.

## 7. References

- Armand, A., Filliat, D. and Ibanez-Guzman, J (2013) "Modelling stop intersection approaches using gaussian processes", In Intelligent Transportation Systems- (ITSC), 16th International IEEE Conference on (pp. 1650-1655). IEEE.
- Autey, J., Sayed, T and Zaki, M (2012) "Safety evaluation of right-turn smart channels using automated traffic conflict analysis", Accident Analysis and Prevention Vol.45, pp.120-130
- Boroujerdian, A., Karimi, A. and Seyedabrishami, S (2014) "Identification of Hazardous Situations using Kernel Density Estimation Method Based on Time to Collision, Case study: Leftturn on Unsignalized Intersection", International Journal of Transportation Engineering, Vol.1, No.4, pp. 223-240
- Dias, C., Iryo-Asano, M. and Oguchi, T (2017) "Predicting optimal trajectory of left-turning vehicle at signalized intersection", Transportation Research Procedia, Vol 21, pp.240-250.
- El-Basyouny, K. and Sayed, T. (2013) "Safety performance functions using traffic conflicts", Safety Science, Vol.51, No.1, pp.160-164.
- Hensher, D.A., Rose, J.M. and Greene, W.H (2005) "Applied choice analysis: a primer. Cambridge University Press".
- Kinovea software from <https://www.kinovea.org/>
- Laureshyn, A., Åström, K. and Brundell-Freij, K (2009) "From speed profile data to analysis of behaviour: classification by pattern recognition techniques", IATSS research, Vol.33, No.2, pp.88-98.
- Li, G., Wang, Y., Zhu, F., Sui, X., Wang, N., Qu, X. and Green, P (2019) "Drivers' visual scanning behavior at signalized and unsignalized intersections: A naturalistic driving study in China", Journal of Safety Research, 71, pp.219-229.
- Li, H., Li, S., Li, H., Qin, L., Li, S. and Zhang, Z (2016) "Modelling left-turn driving behaviour at signalized intersections with mixed traffic conditions", Mathematical Problems in Engineering, Hindawi Publishing Corporation.

## Analysis of Speed Profiles at An Unsignalised Intersection for Left Turning Vehicles

DOI:<http://dx.doi.org/10.1155/2016/4015271>

-Liu, M., Chen, Y., Lu, G. and Wang, Y (2017) "Modelling crossing behaviour of drivers at unsignalized intersections with consideration of risk perception", *Transportation research part F: traffic psychology and behaviour*, Vol 45, pp.14-26.

-Lu, G., Liu, M., Wang, Y., & Yu, G (2012) "Quantifying the severity of traffic conflict by assuming moving elements as rectangles at intersection", *Procedia-Social and Behavioral Sciences*, Vol.43, pp.255-264.

-Lu, G., Liu, M., Wang, Y., Wan, H. and Tian, D (2015) "Logit-Based analysis of drivers' crossing behaviour at unsignalized Intersections in China", *Human factors*, Vol.57, No.7, pp.1101-1114.

-Ma, Z., Xie, J., Qi, X., Xu, Y. and Sun, J (2017) "Two dimensional simulation of turning behaviour in potential conflict area of mixed flow intersections", *Computer Aided Civil and Infrastructure Engineering*, Vol 32, No 5, pp.412-428

-Patil, G.R. and Pawar, D.S (2016) "Microscopic analysis of traffic behaviour at unsignalized intersections in developing

world", *Transportation Letters*, Vol 8, No 3, pp.158-166.

-Platho, M., Groß, H.M. and Eggert, J (2013) "Predicting velocity profiles of road users at intersections using configurations", *In Intelligent Vehicles Symposium (IV)*, 2013 IEEE, pp. 945-951.

-Sun, J., Zhou, S.E., Li, K. and Ni, Y (2012) "Evaluation of safety factors at Chinese intersections", *In Proceedings of the Institution of Civil Engineers-Transport (Vol. 165, No. 3, pp. 195-204)*. Thomas Telford Ltd.

-Wolfermann, A., Alhajyaseen, W.K. and Nakamura, H (2011) "Modelling speed profiles of turning vehicles at signalized intersections", *In 3rd International Conference on Road Safety and Simulation RSS2011*, Transportation Research Board TRB, Indianapolis, pp 1-17.

-Zhang, G., Qi, Y. and Chen, J (2016) "Exploring factors impacting paths of left-turning vehicles from minor road approach at unsignalized intersections", *Mathematical Problems in Engineering*, Hindawi Publishing Corporation.

DOI:<http://dx.doi.org/10.1155/2016/1305890>